



Electric wire rope hoists

ABUS
CRANE SYSTEMS

QUALITY AT YOUR FINGERTIPS



ABUS GM wire rope hoists

Absolute reliability is one of the most important features for a wire rope hoist. To ensure the highest possible reliability levels in everyday operation, our crane systems are made to the most stringent quality standards. ABUS GM electric wire rope hoists are produced using the most advanced technology available and continue to bear witness to their reliability, safety and durability year after year, from motor to rope, gearbox, brakes and electrical and electronic systems. Apart from quality, versatility is an outstanding feature of ABUS

GM electric wire rope hoists. These units cover an extremely wide load capacity range, from 1,000kg to 120 tonnes. And the comprehensive standard equipment means that even a standard ABUS electric wire rope hoist is a versatile unit right from the start. Additional equipment is also available for special applications. Order an ABUS GM electric wire rope hoist and you can be sure that you have opted for a top-quality material handling unit.

WE DELIVER THE SOLUTION



Type D crab units on double girder overhead travelling cranes



Type E monorail hoist on a type VS pillar jib crane



Type E monorail hoists on type ELV single girder overhead travelling cranes.



Type E monorail hoist on a type EDL underhung overhead travelling crane

ABUS MODULAR WIRE ROPE HOIST: TECHNICAL INTELLIGENCE IN TOP SHAPE



The modular ABUS wire rope hoist covers the load capacity range up to 5 t, 2 fall in the range 1 t – 2.5 t and 4 fall from 2 t to 5 t.

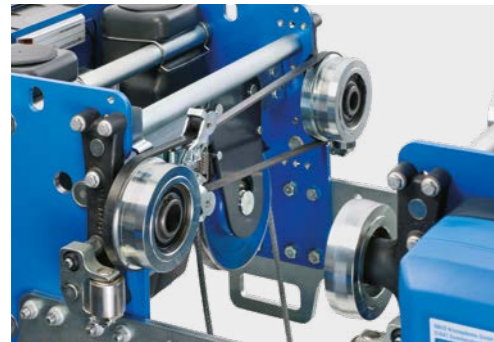

The modular wire rope hoist is driven by a trolley travel motor operated with a frequency converter. The hoist drive has a 4-pole hoist motor with frequency converter control as standard. The lifting speed can be either infinitely adjustable or used to simulate pole switching. The maximum lifting speed is load-dependent and achieves double the nominal lifting speed when running empty. A patented inductive measurement technique guarantees the load measurement even when the hoist is at a standstill.



The reeving of the wire rope hoist can be converted: from 4 fall (4/1) to 2 fall (2/1) and vice versa. This is of benefit if the operating conditions change or the wire rope hoist is to be sold. The conversion is quick and easy, since the deflection roller crosshead and the fixed point crosshead are mounted through a reliable bolt connection on the trolley frame and can be easily changed as required. The ABUS modular wire rope hoist is equipped with adjustable and cushion-mounted track guide rollers as standard and thus preserves the lower flange of the crane.



MODERN, FUNCTIONAL APPEARANCE AND HIGH-QUALITY COLOUR CONCEPT.

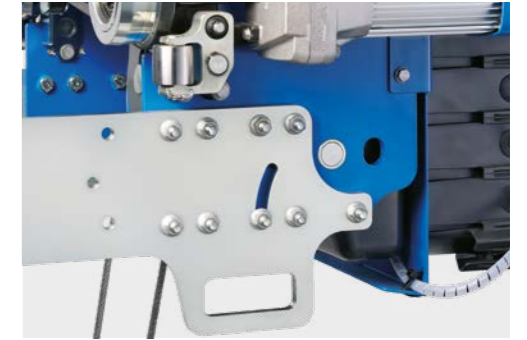

The convenient folding mechanism makes assembly of the wire rope hoist on the crane very simple.

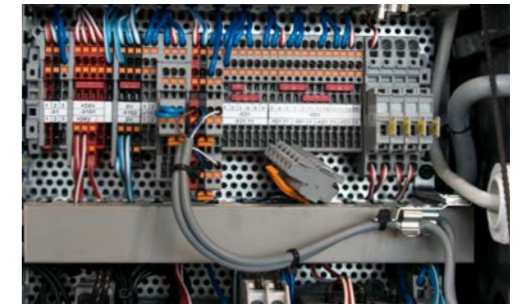

The switch cabinet of the wire rope hoist has a modular design: all components are 'plug and play' and can be purchased on the open market from well-known manufacturers – a huge service advantage!

Model	GM800m		GM1000m	
	2/1	4/1	2/1	4/1
Reeving	1.0	2.0		
SWL (t)	1.25	2.5	2.5	5.0
	1.6	3.2		
Hook path (m)	12	6	12	6
	18	9	18	9
C (mm)	540	427	567	500
H (mm)	217	217	217	217

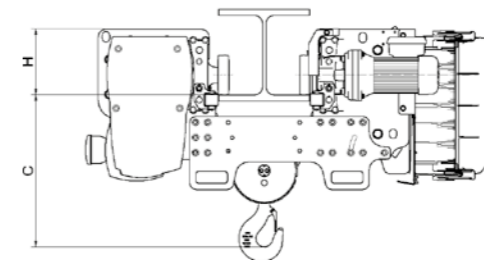

The trolley frame consists of bolted and compressed side walls. This innovative and patented type of connection from ABUS impresses with its high precision and stability.



The modular wire rope hoist is equipped with an LED matrix display, which shows various operating information of the ABUControl crane control as well as the status reports of the crane components. Errors can thus be quickly and easily identified and eliminated. The LED display shows the characters with plenty of contrast and can be easily read.

ABUS GM WIRE ROPE HOISTS - QUALITY FEATURES

Hoisting gear



Lightweight gear units with silent-running flat bevelled gears deliver the torque required. Four different gear ratios are available for each model.

Hoist motor



Sturdy pole change motors with cylindrical rotors and integrated safety brakes are the powerhouse of ABUS wire rope hoists.

Rope guide

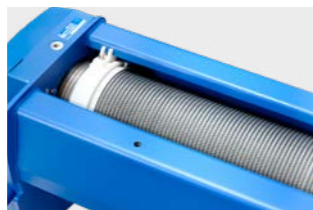

A resilient low-friction plastic rope guide designed as an expanding ring provides positive guidance for the rope. The rope guide also reduces wear on the rope and rope drum. It is also easy to install, reducing maintenance requirements for the unit as a whole.

Bottom block

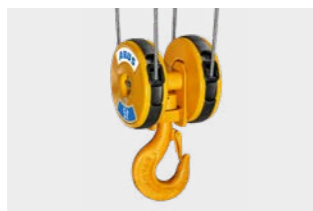

The elegant bottom blocks are equipped with edge protectors around the rope opening. Long service lives and high safety levels are outstanding features of the resilient annealed steel rollers with machined rope grooves and annealed load hooks.

Safety brake



The dual-disk electromagnetic brake features automatic braking in the event of a power failure. Asbestos-free brake linings designed for approx. 1 million braking operations make for long maintenance intervals.

2 CROSS TRAVEL SPEEDS AND GALVANIZED ROPE AS STANDARD FEATURES

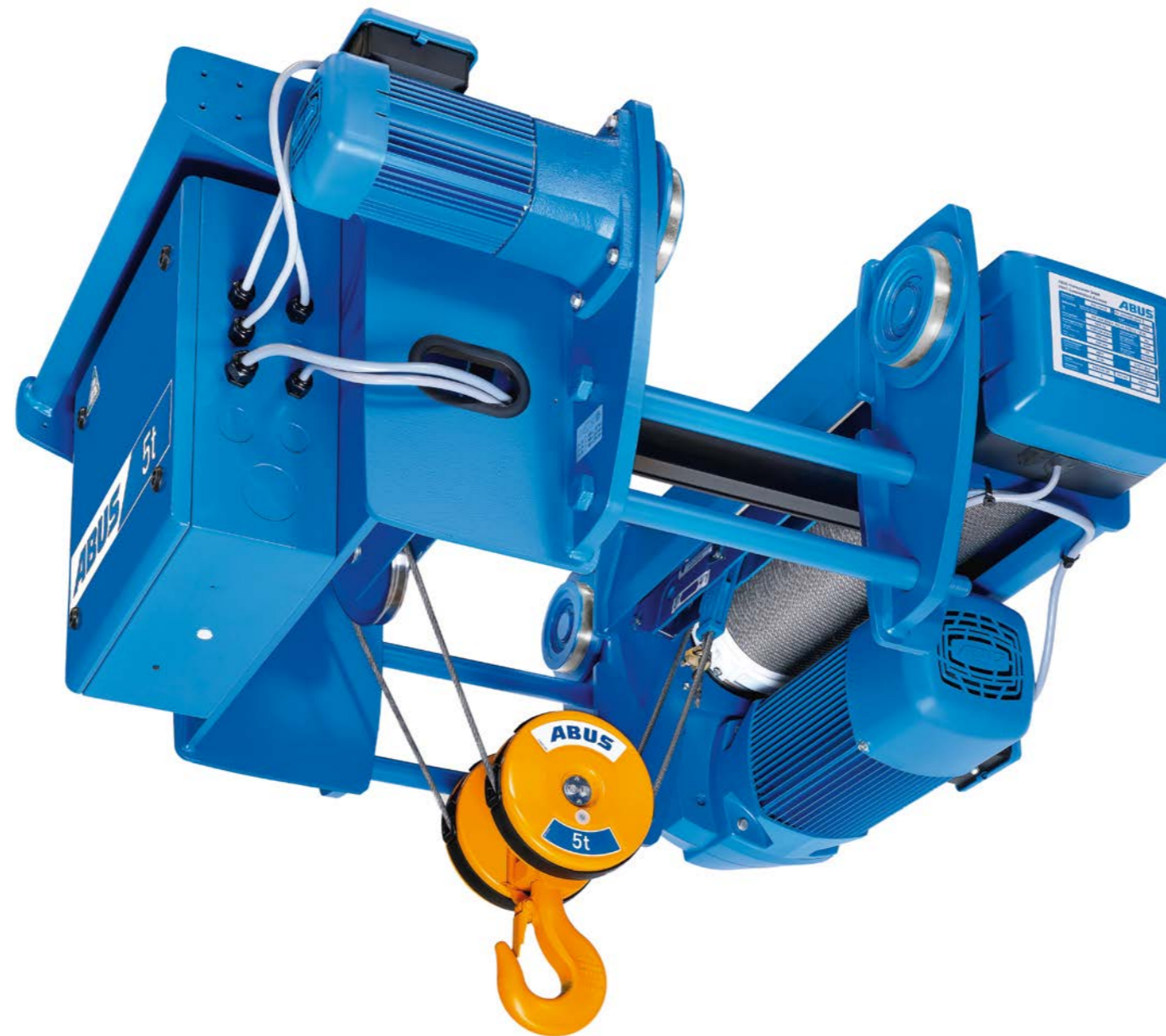

Cross travel drive



Two compact epicyclic reduction gears with pole-changing brake motors directly drive two wheels.

Electrical system



The easy-to-service control system with ABUS LIS control unit includes motor protection functions, operating hours meter and overload protection function.

Cross travel trolley



Hoist trolleys are fitted with four flanged wheels with permanently lubricated roller bearings, designed for use on tracks with parallel flanges. Wheels for tracks with inclined flanges are available as an option.

Easy plug-in connector



The factory fitted ABUS plug and socket connections reduce installation and maintenance work to a minimum. Connections are easy to assemble and dismantle. Furthermore incorrect connections are impossible.

ABUS emergency limit switch



Two standard switching points for the highest hook position ensure double safety.

ABUS ELECTRIC WIRE ROPE HOISTS – THE TECHNOLOGY

GM electric wire rope hoists demonstrate the high quality level achieved by ABUS:

- developed using advanced calculation and CAD programs
- future-oriented technology: two-speed hoist and cross travel drives, standard motor protection functions
- made and tested at advanced production facilities, with an ISO 9001 quality system ensuring constant high levels of quality
- optimized by continuous incorporation of experience obtained in testing and use
- reliable, durable units for load capacities from 1t to 120t with the CE mark for use in the European Economic Area; 7 basic types available in various models with speeds, lifting heights and drive groups for a wide range of applications.

Hoist design

ABUS wire rope hoists are extremely compact units, robust and easy to maintain, which can easily stand up to comparison with the competition. Outstanding design features include the parallel configuration of rope drum and hoist motor, modular design and the functional arrangement of all components. Joints with direct fits between components such as hoist motor, gears, rope drum and limit switches save parts and improve reliability. Modular hoist motors increase flexibility in type selection and facilitate potential service requirements.

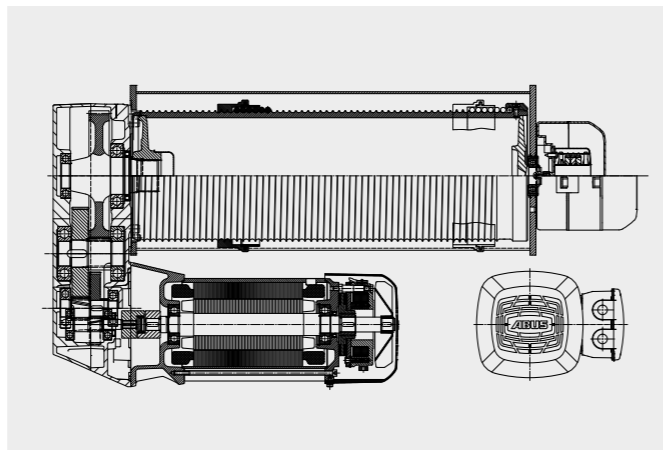

Hoist motors

ABUS uses sturdy cylindrical rotor pole change motors with elegant continuous cast aluminium sections, integrated safety brakes and easy-to-use plug and socket connectors. Hoists are supplied as insulation class F, IP55 protected units. Stator subdivisions are optimized for higher electrical efficiency, smooth running and improved thermal capacity in service with frequent switching operations, allowing smaller sizes compared with conventional motors. Automated winding production ensures reproducible quality.

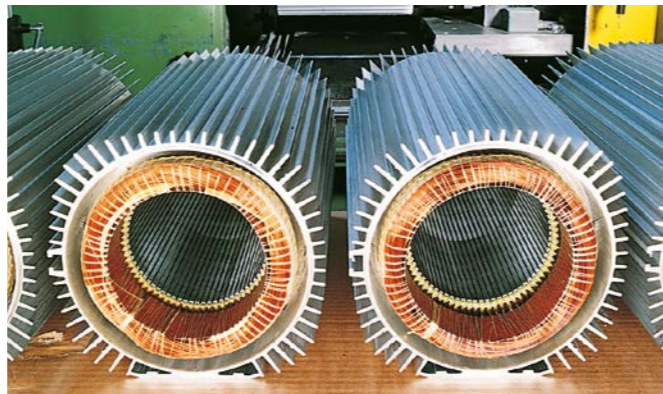

Hoist gears

Precision flat bevelled gear units in light alloy housings with case-hardened gears, high-grade surface treatment and permanent oil lubrication ensure high reliability and smooth running with a minimum of maintenance.

Hoist brakes

Dual-disk electromagnetic brakes ensure automatic braking on power failure. Environmentally sound brake linings designed for approx. 1 million braking operations allow long maintenance intervals.

ABUS wire ropes

- improved tensile strength
- enhanced fatigue strength under cyclic bending stresses
- high structural coherence
- improved abrasion resistance
- enhanced corrosion protection

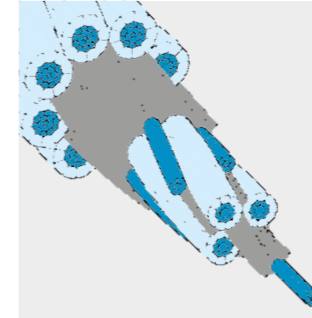

Rope drive

Low weight and compact dimensions are top priorities in the ABUS design brief, which is why ABUS development engineers have selected high-strength galvanized wire ropes with compacted strands and a special structure for use on ABUS wire rope hoists. Combined with wear-resistant rope drums and rollers, these ropes make it possible to produce an extremely compact rope drive without making any sacrifices in terms of reliability and durability.

Supporting structure, trolleys and drive systems

The hoist types described on pages 10 to 14 are the result of integrating standard hoists in chassis designed for different applications and combining them with various types of travelling gear. Compact dimensions, low headroom dimensions, favourable end approach dimensions, practicality and quality are outstanding features of all these hoists. In the case of crab units, the supporting structure is connected to the end carriages by machined joints and bolts, allowing accurate wheel positioning to precision engineering standards. In addition, articulated end carriage joints ensure that all four wheels are always firmly positioned on the tracks and that the wheel loads on the crane bridge are properly distributed in accordance with the structural design of the system. The travelling gear includes flanged wheels with roller bearings. In combination with individual drive systems, they form compact direct drive units requiring almost no maintenance. As regards mains operation, pole change cylindrical rotor motors with smooth start-up characteristics, additional balance weights on the motor shaft and integrated disk brakes make for smooth acceleration and braking almost unaffected by the load on the system. Other optional features available for even smoother running include smooth starting units and smooth switching relays.

Rope drums

Developed and optimized with the aid of finite element simulation programs

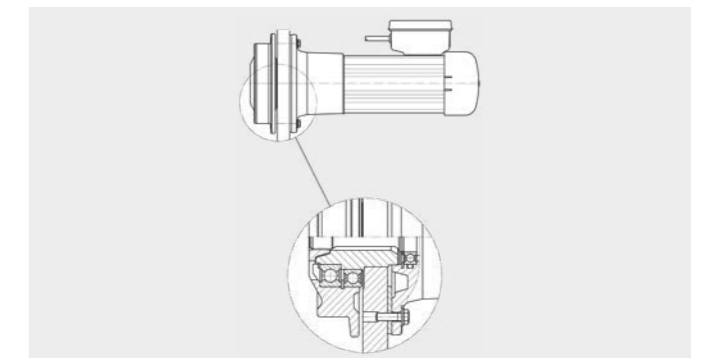
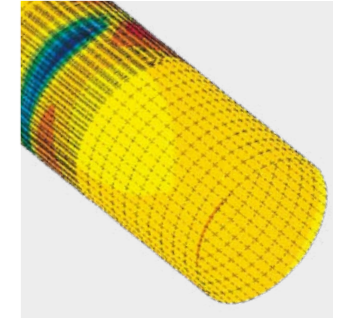

Electrics

The control systems used for ABUS wire rope hoists feature proven technology and are of modular design, covering a very wide operating range. All motion functions are designed for two-stage pole change operation. The systems are designed for ease of installation and maintenance and reliable operation, with fuseless circuitry, ducted wiring and non-screwed terminals

ABUS GM WIRE ROPE HOISTS FOR SINGLE-GIRDER CRANES

Type E – monorail hoist

A compact designed monorail hoist with low headroom dimensions and two direct drive cross travel motors. The cross travel trolley is adjustable to suit various flange widths. These most cost effective and frequently ordered hoists have a load range from 1 t to 16 t SWL.

Model	Reeving	Load cap. (t)	Hook path (m)			C (mm)	H (mm)
GM 800	4/1	3.2	6	9	-	400	176
GM 1000	2/1	2.5	12	18	24	567	196
	4/1	5.0	6	9	-	500	196
GM 2000	2/1	3.2	12	18	24	580	213
	4/1	6.3	6	9	-	500	213
GM 3000	2/1	6.3	12	20	30	665	251
	4/1	10.0	6	10	15	580	251
	4/1	12.5	6	10	-	580	251
GM 5000	2/1	10.0	12	20	30	830	273
	4/1	16.0	6	10	-	825	273
GM 6000	2/1	10.0	12	20	-	830	293
	2/1	12.5	12	-	-	830	293

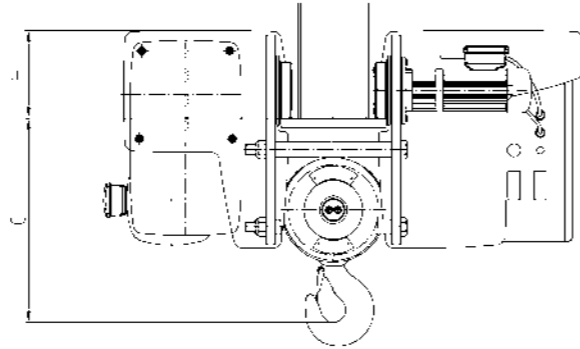

Type U – monorail hoist with twin trolleys

A monorail hoist with twin trolleys for high load capacities and long hook paths. Cross travel trolley designed for direct drive without exposed reduction gearing. As the load is distributed over eight wheels, ordinary rolled section beams can be used for monorail track applications. With short spans, even high-load cranes can be operated on ordinary rolled section beams using this hoist. Load capacity range: 6.3 t to 25 t.

Model	Reeving	Load cap. (t)	Hook path (m)			C (mm)	H (mm)
GM 5000	4/1	20.0	6	10	15	1132	180
GM 6000	2/1	12.5	12	20	30	1256	180
	4/1	25.0	6	10	15	1241	180
GM 7000	2/1	20.0	16	30	45	1615	180

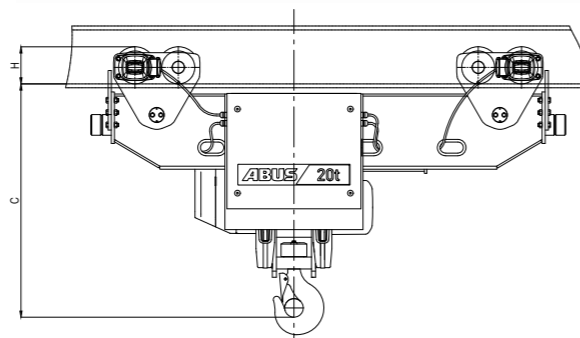

Type S – side-mounted hoist

With its optimized hook height, this hoist, which can be used on crane bridges with a span of up to 35m or more, has advantages over other types in terms of investment return.

- Compared with a single girder crane crane using a type E monorail hoist, the building height can be reduced.
- Compared with a double girder crane crane of about the same height, the loads on the crane track and the building are significantly lower.

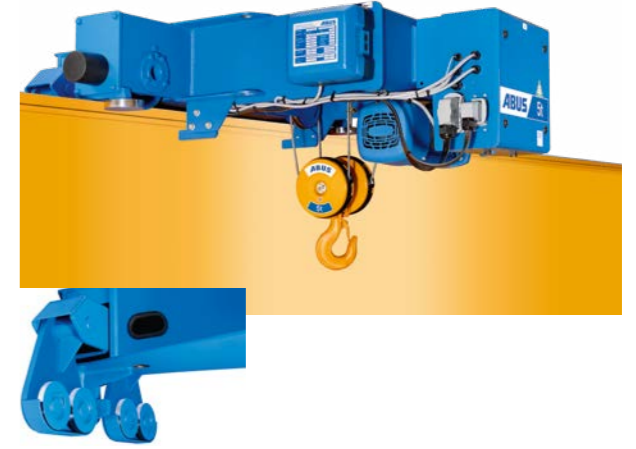

Support rollers with swivel mount

Model	Reeving	Load cap. (t)	Hook path (m)			C (mm)	H (mm)
GM 800	4/1	3.2	6	9	-	343	250
GM 1000	4/1	5.0	6	9	-	420	290
GM 2000	4/1	6.3	6	9	-	440	290
GM 3000	2/1	5.0	12	20	-	700	290
	4/1	10.0	6	10	15	555	360

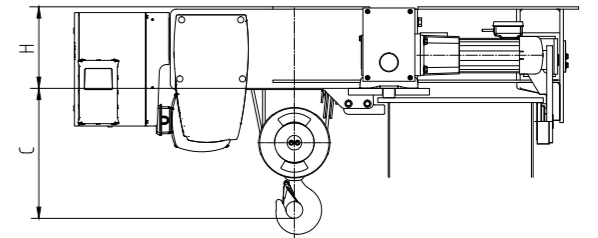

Comparison of the headroom of different hoists, SWL 10 t, span 25 000 mm

Single girder crane with type E monorail hoist

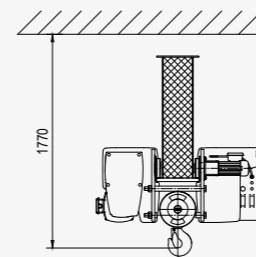

ELK

Double girder crane with type D crab unit

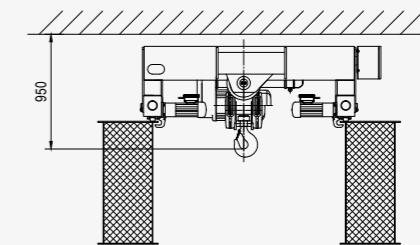

ZLK

Single girder torsion box crane with type S side-mounted hoist

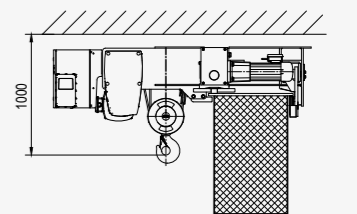

ELS

ABUS GM CRAB UNITS FOR DOUBLE-GIRDER CRANES

Type D – standard crab unit

A compact designed crab unit for the medium load capacity range, with articulated end carriage joints ensuring positive contact of all four wheels with the track, with two direct drive cross travel motors. Load capacity range: 1 t to 63 t.

Model	Reeving	Load cap. (t)	Hook path (m)			C (mm)	H (mm)	
GM 800	4/1	3.2	6	9	-	149	465	
GM 1000	4/1	5.0	6	9	12	200	505	
GM 2000	2/1	3.2	12	18	24	300	505	
	4/1	6.3	6	9	12	220	505	
GM 3000	2/1	6.3	12	20	30	320	565	
	4/1	12.5	6	10	15	260	595	
GM 5000	2/1	10.0	12	20	30	37	445	615
	4/1	20.0	6	10	15	18.5	385	720
	4/2 ¹⁾	10.0	9	15	20	-	320	615
GM 6000	2/1	12.5	12	20	30	37	520	660
	4/1	25.0	6	10	15	18.5	275	900
	6/1	40.0	4	6.6	10	12.3	611	950
GM 7000	2/1	20.0	16	30	45	-	572	987
	4/1	40.0	8	15	22.5	27.5	500	995
	4/2 ¹⁾	20.0	7.3	17	27.3	-	236	987
	6/1	63.0	5.3	10	15	-	897	1218
	8/2 ¹⁾	40.0	4.2	9	14.2	-	521	1020

¹⁾ True vertical lift (without hook movement or turn)

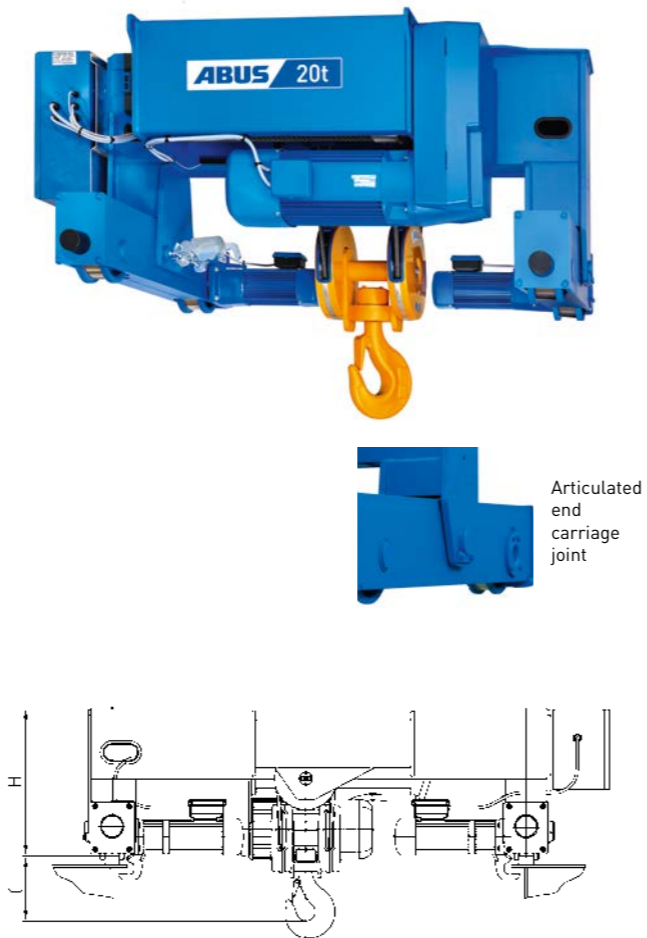

Type DA – low headroom crab unit

In contrast to type D, the supporting member with the hoist between the end carriages is equipped with articulated joints. The hoist headroom is therefore reduced to a minimum. This is the option to use where very little space is available above the crane, as an alternative to type DQA, also a low headroom option. ABUS advisors will be happy to provide you with technical data and dimensions.



Type DQA – ultra low headroom crab unit

An ultra low headroom crab unit with the rope drum axis in the direction of cross travel, articulated end carriage joints ensuring positive contact of all four wheels with the track, two direct drive cross travel motors. Load capacity range: 1 t to 40 t. ABUS advisors will be happy to provide you with technical data and dimensions.



Type Z – twin barrel crab unit

A compact designed crab unit with twin barrels and articulated end carriage joints ensuring positive contact of all four wheels with the track, two direct drive cross travel motors. Load capacity range: 8 t to 120 t.

Model	Reeving	Load cap.(t)	Hook path (m)			C (mm)	H (mm)	
GM 5000	4/2	20.0	12	20	30	37	413	985
	8/2	40.0	6	10	15	18.5	635	1060
GM 6000	4/2	25.0	12	20	30	37	419	1035
	8/2	50.0	6	10	15	18.5	643	1105
GM 7000	4/2	40.0	16	30	45	-	668	1220
	6/2	63.0	10.6	20	30	36	897	1218
	8/2	80.0	5	15	22.5	27.5	915	1275
	10/2	100.0	12	18	22	-	960	1265
	12/2	120.0	15	18	-	-	1400	1200

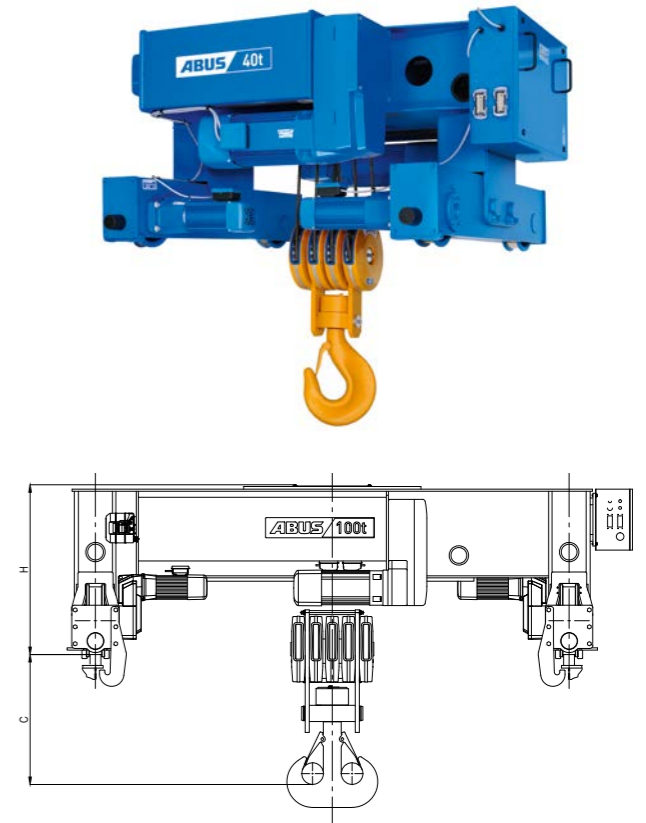

Type ZA – low headroom twin barrel crab unit

In contrast to type Z, the supporting member with the hoist between the end carriages is equipped with articulated joints. The hoist headroom is therefore reduced to a minimum. This is the option to use where very little headroom is available above the crane. ABUS advisors will be happy to provide you with technical data and dimensions.



Cross travel drives

Wheel diameter
≤ 280 mm
Epicyclic geared motors



Wheel diameter
≥ 350 mm
Flat-geared motors



EXPLANATION OF TYPE DESIGNATION

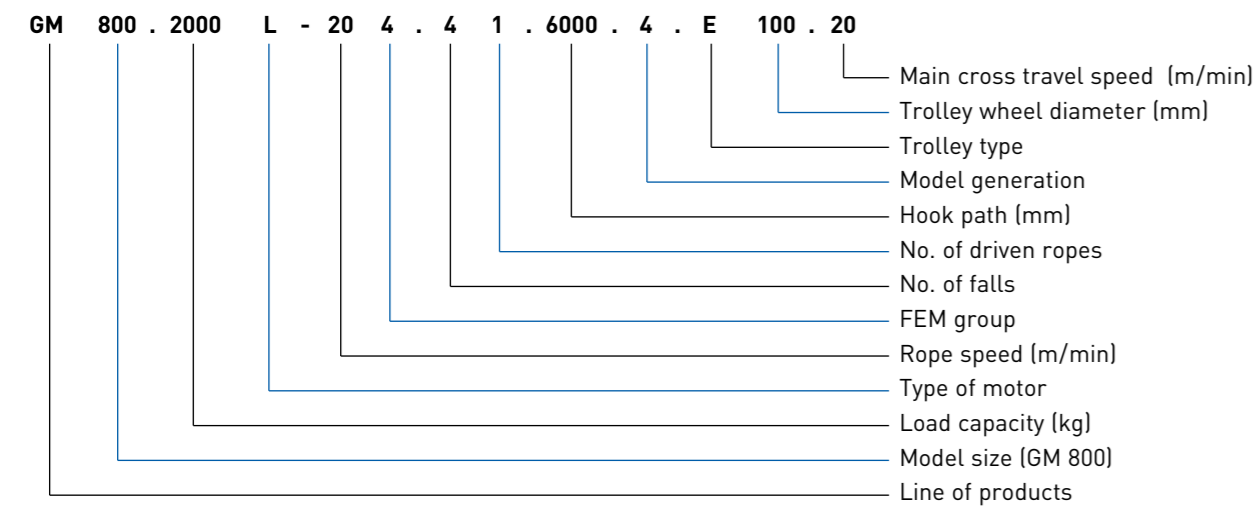

Previous designation:
GM 820 L6-204.41.06.3.E

New designation (36 – 43 characters):
GM 800.2000L-204.41.6000.4.E 100.20

REEVING OF THE ABUS ELECTRIC WIRE ROPE HOISTS

Type 2/1 – E, D, U

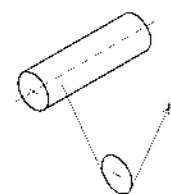

Type 4/2 – D

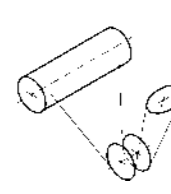

Type 6/2 – Z

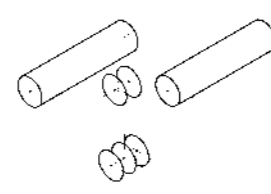

Type 4/1 – E, D, U

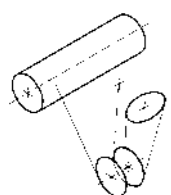

Type 8/2 – D

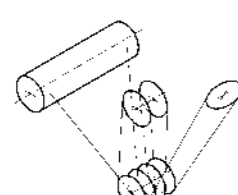

Type 8/2 – Z

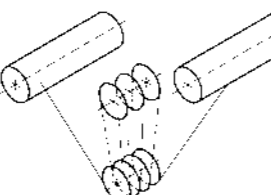

Type 6/1 – D

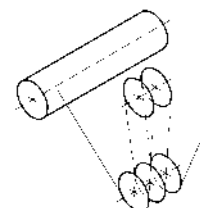

Type 4/2 – Z

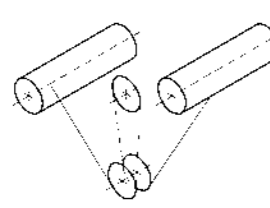

Type 10/2 – Z

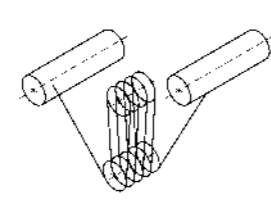

Type 12/2 – Z

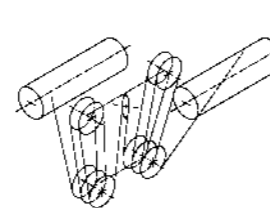

A SUBJECT YOU CANNOT AFFORD TO NEGLECT: DRIVE GROUP (FEM GROUP) SELECTION

Apart from the type of hoist required, the load capacity, the hook path and the lifting speed, the drive or FEM group is one of the main criteria to consider when selecting a hoist. The drive group must be selected to ensure that the hoist is used for its intended purpose. Standard hoists are normally designed for a mean theoretical service life of 10 years, subject to operation in accordance with FEM 9.511. If the drive group selected is not appropriate in view of actual service conditions, the actual service life may be considerably shorter than 10 years. The results are excessive expenditure for maintenance, repairs and overhauls. The crane operator is under an obligation to take appropriate action to ensure that the expended portion of the service life does not exceed the theoretical service life stated in the operating instructions. When the theoretical service life has expired, the hoist must be decommissioned. Continued operation is allowed if it has been determined that there are no objections to continued operation and the conditions for continued operation have been defined. Normally, a full overhaul of the hoist will be required. In general, the inspector requires the hoist to be overhauled. The objective of these requirements is to ensure that each hoist is only operated within its safe working period (S.W.P.).

The following table indicates the theoretical service life D in hours for FEM groups 1Bm, 1Am, 2m, 3m and 4m.

Line	Drive group load spectrum	Theoretical service line D (h)				
		1Bm/ M3	1Am/ M4	2m/ M5	3m/ M6	4m/ M7
1	light	3200	6300	12500	25000	50000
2	medium	1600	3200	6300	12500	25000
3	heavy duty	800	1600	3200	6300	12500
4	very heavy duty	400	800	1600	3200	6300

In addition to the mean working time per day, t_m (total hours cumulated of operation of the hoist per day), the correct assessment of the load spectrum is essential for selecting the appropriate drive group. The value t_m is given by the following equation:

$$t_m = \frac{2 \times \text{mean lifting height (m)} \times \text{load cycles (1/h)} \times \text{working time (h/day)}}{60 \text{ (min/h)} \times \text{lifting speed (m/min)}}$$

Mean lifting height:

the average hook travel under actual operating conditions

Load cycles:

the average number of lifting operations per hour. A load cycle consists of one lifting and one lowering operation, i.e. two hook movements (lifting operations with an empty hook as a result of process conditions must also be taken into account in determining load cycles, but also make the load spectrum determined less severe).

Working time:

average working time per day within which the above-mentioned average load cycles per hour are performed.

Lifting speed:

average lifting speed (normally the maximum lifting speed) at which the load cycles are performed.

The selection of the next highest FEM group results in a doubling of the theoretical service life if the operating conditions assumed remain unchanged. FEM 9.755 gives more detailed information on this complex subject.

If the mean working time t_m and the load spectrum are known, the correct drive group in accordance with DIN 15020 or FEM 9.755 can be selected using the following table.

Load spectrum	Definition of load spectrum	Mean working time t_m per working day in h				
1 (light)	[k ≤ 0,50] only operated at maximum load in exceptional cases, mainly operated at very low load, small dead load	≤ 2	2 - 4	4 - 8	8 - 16	> 16
2 (medium)	[0,50 < k ≤ 0,63] operated quite frequently at maximum load, operated continuously at low load, medium dead load	≤ 1	1 - 2	2 - 4	4 - 8	8 - 16
3 (heavy duty)	[0,63 < k ≤ 0,80] operated frequently at maximum load, operated continuously at medium load, heavy dead load	≤ 0,5	0,5 - 1	1 - 2	2 - 4	4 - 8
4 (very heavy duty)	[0,80 < k ≤ 1] operated regularly at maximum load, very heavy dead load	≤ 0,25	0,25 - 0,5	0,5 - 1	1 - 2	2 - 4

Drive/FEM group in accordance with DIN 15020 or FEM 9.511

1Bm 1Am 2m 3m 4m

ACCESSORIES

ABUS LIS control system – the nerve centre of your ABUS wire rope hoist

ABUS wire rope hoists are equipped with an intelligent LIS control system, available in two versions – LIS-SE and LIS-SV. Both versions feature an overload protection device which reliably protects the hoist against overloading. While the LIS-SV uses a strain gauge signal to measure the load, the LIS-SE calculates the current load on the hook on the basis of three-phase current and voltage measurements made while the motor is running.

Both types of control unit may be equipped with an optional load display for visualizing the load. All LIS control units are equipped with an operation hours meter for determining the expended portion of the service life. For precise determination of the remaining service life, a load population recorder in accordance with FEM 9.755 is available as an option. This ensures safe working periods over the entire service life of the hoist. The load population recorder is designed to allow the relevant values to be read out easily by the operator. In addition to these features, LIS control units are designed for a number of other functions to ensure safe, low-maintenance operation of all ABUS wire rope hoists. The combination of actively fail-safe electric and electronic circuitry meets the highest safety requirements and is in accordance with the diversity and active fail-safe requirements of the applicable standards.

The integrated motor overcurrent protection system and the guided start-up function reliably protect the hoist motor against thermal overloading, provided that a proper use is given. If the motor current continuously exceeds the maximum value, the overcurrent protection function shuts down the motor. The guided start-up function prevents excessive inching operation when the high hoist speed is selected. Another function with considerable benefit to the user is regenerative braking. During each braking operation from high hoist speed, the motor is briefly operated as a generator to slow the hoist before the mechanical brakes are operated, significantly extending the service life of the brake linings.

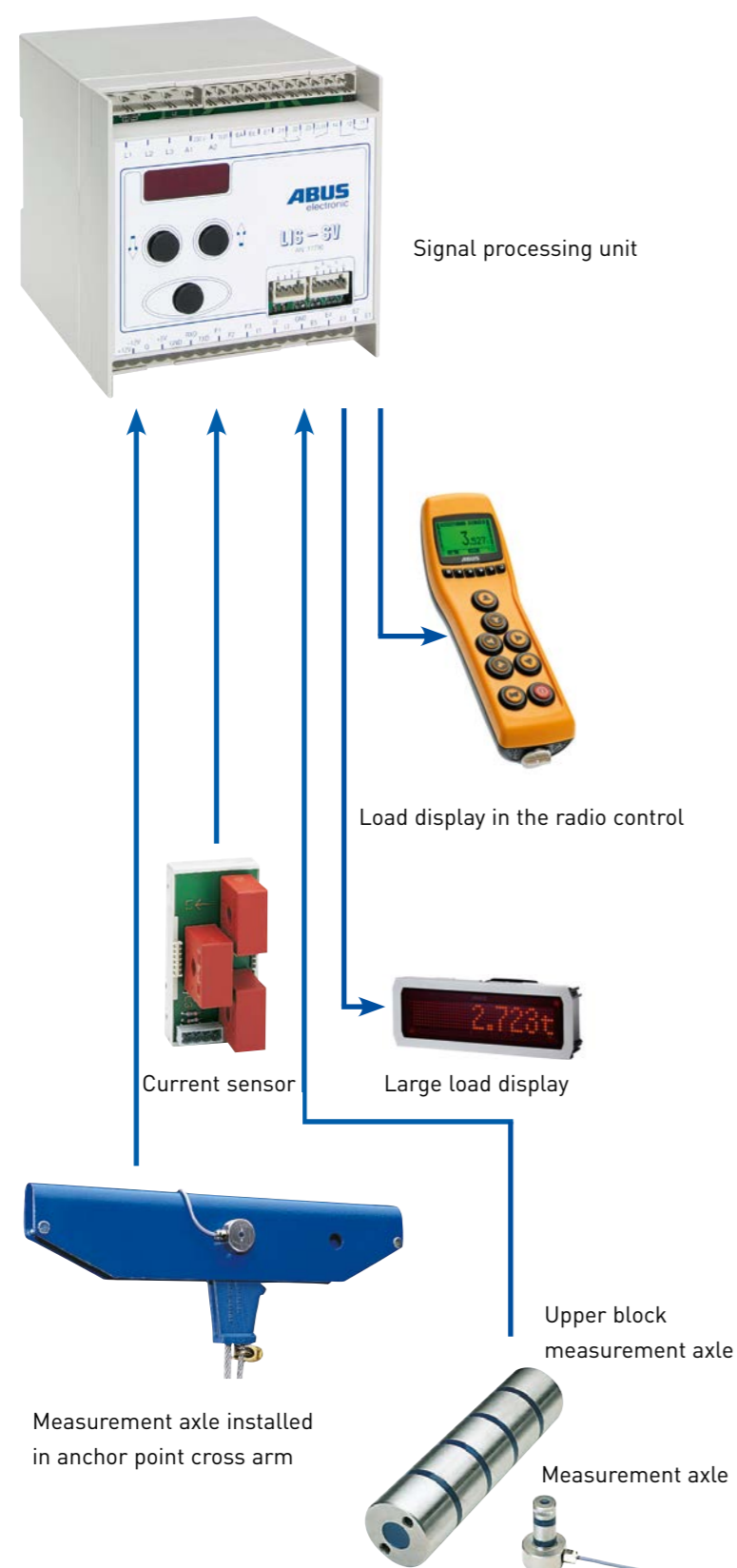

The ABULiner

is an effective solution when precise positioning is required with variable speed hoists. This frequency converter also allows the maximum speed to be increased above the rated speed when lifting part/reduced loads. ABULiners are also available for long and cross travel.

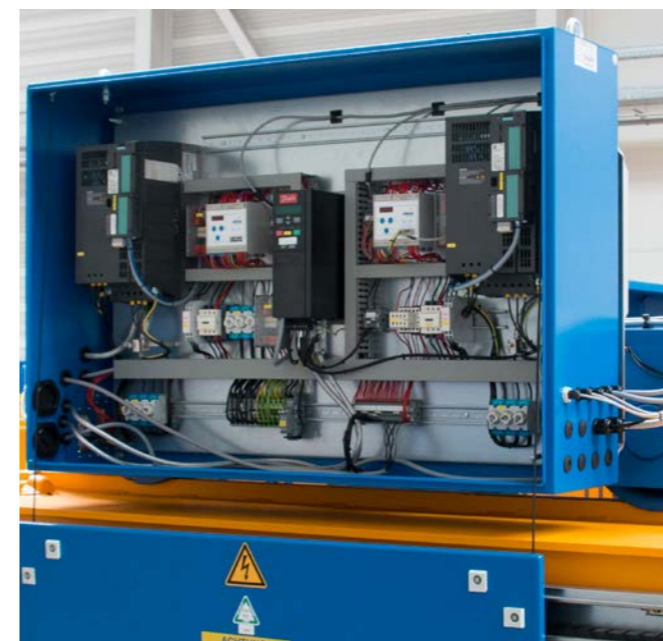

Anti-sway motion sequences with two speed operation

For those wanting to optimally transport sensitive or large loads, ABUS is expanding its pole-switchable system with the AZS smooth starting unit and the SU-2 smooth switching relay. These electronic systems are adjustable and allow the crane operator to use the acceleration and improved deceleration characteristics for sensitive control of the long and cross travel motions as an alternative to the frequency converter.



Calibrated weighing hook

Knowing what is hanging on the hook is important for many crane operators: weighing goods and invoicing them to customers, loading trucks, charging production plants with weighed material, complying with safety regulations for loads or determining the weight of containers - the ABUS weighing hook block is often the economically advantageous solution. It is a digital commercial scale of accuracy class III with EU approval from the German National Metrology Institute. The crane scale is calibrated and delivered ready for operation. The weighing electronics consist of modern SMD technology in a robust industrial design. The weighing module integrates optimally into the bottom block of ABUS wire rope hoists.



Stooled down crab units allow double girder overhead travelling cranes to be installed even where there is little space above the crane track. The higher position of the crane bridge with a stooled down crab unit may be a decisive advantage, for example when handling bulky machines or large tanks.

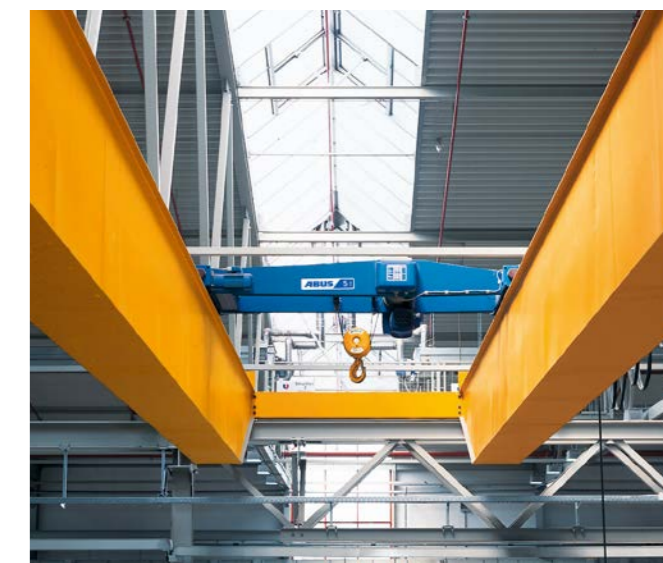

Optional twin hoist operation for the transport of particularly heavy and bulky loads. The wire rope hoists are controlled from the crane control either individually or as a pair. A real safety advantage for your transport task.



Further possible options are available on our website. Or simply contact us.

ABUCONTROL: LIFTS CRANES TO A NEW LEVEL

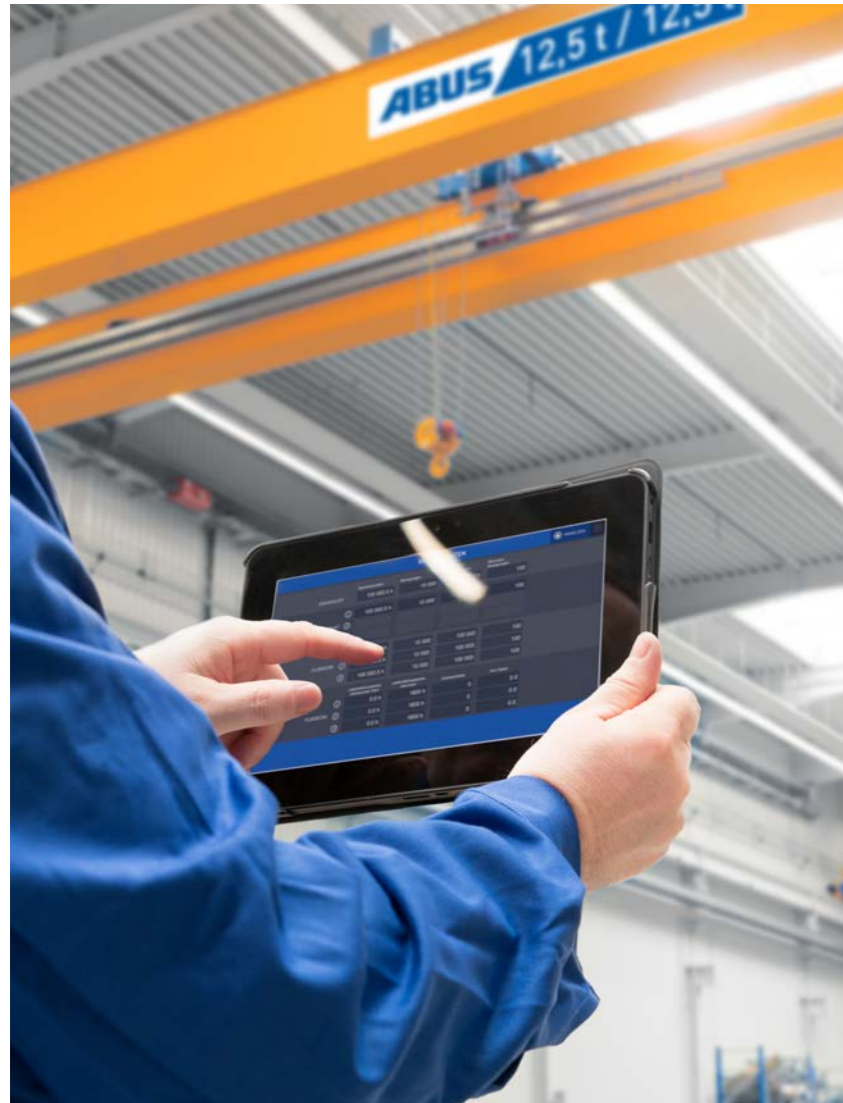

ABUS cranes with control via ABUControl can be adapted to your application by the means of travel profiles. Cranes with two fixed speeds move in a completely different way to cranes controlled by frequency converter, for example. **Travel and hoist profiles** allow cranes to be adapted to your current or required situation. This eliminates the need for your crane operators to adjust existing cranes, making them more likely to feel the increased productivity from the additional crane system.



The **ABUS sway control** increases safety and convenience during transportation of goods in sensitive areas. Sway control is based on mathematical calculations. Travel speeds, acceleration and deceleration of crane and hoist, the hook position and length of the load lifting attachment are taken into account. Even people who rarely operate cranes can transport loads safely with the aid of the sway control feature.



The **ABUS synchronisation** control of two hoists on one crane makes the safe handling of long products possible. Divergence of lifting speeds is prevented effectively through constant regulation even where different wire rope hoists are used. This requires the crane to be equipped with a frequency converter for lifting. Travel speeds are regulated even on cranes which run in tandem. Two cranes, maximum of four hoists and their hoisting motions, all regulated.



Operating data, settings, service information. Thanks to the modern KranOS interface, you can keep tabs on the crane. For wireless use with any laptop or tablet with browser. Speeding up regular annual inspections into the bargain.

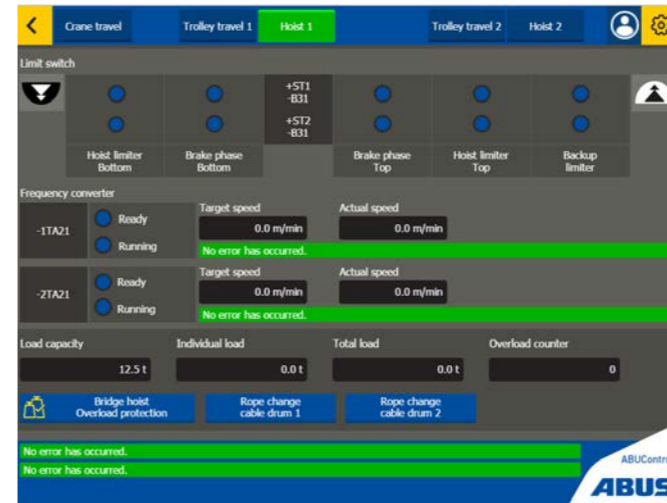

ABUControl relies on tried-and-tested freely available components from renowned electronics manufacturers. Replacement or repair requires neither 'specialist knowledge' nor 'software licences'. You remain in complete control of the crane at all times and have a free choice of service partner. ABUControl - a unique promise for simple maintenance and repairs.

ABUS QUALITY STANDARDS: PRECISE, MODERN PRODUCTION PROCESSES

Shot blast plant for wire rope hoist side plates



The structural steel construction of the trolley frames is carried out with the aid of a welding robot. This ensures short throughput times and consistent welding performance.

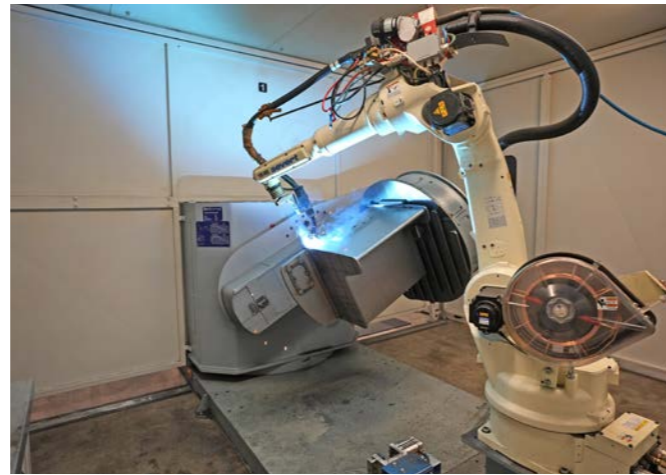

Advanced CNC lathes are used to turn the rope drums in one operation, an approach that ensures perfectly smooth running of the rope drums during operation.



Mechanical machining of the wire rope hoist housing on 4-axis milling centres



Corrosion protection and surface finishing using water-based paints



Final assembly and functional tests





ABUS CRANE SYSTEMS – GETTING INTO THE NUTS AND BOLTS OF MATERIALS HANDLING SOLUTIONS



ABUS deliberately specialises in off-floor lifting and load handling systems for loads up to 120t. Not only because this load range includes by far the majority of all materials handling applications, but also because specialisation enables us to utilise rationalisation potential most effectively. ABUS offers a comprehensive range of readily available, efficient load handling systems: jib cranes, overhead cranes, monorail trolley tracks, electric wire rope and chain hoists, a wide variety of components and, last but certainly not least, the HB light crane track systems. Our services range from the development of solutions for bespoke applications right

through to implementing complete materials handling systems. ABUS crane systems – getting into the nuts and bolts of materials handling solutions. And all our services are characterised by the special ABUS attitude: we offer not only a bare product, but also practical advice and assured quality. The product guarantee which we offer is still unique in our field and individual user support and a nationwide after-sales service network with rapid, effective response are all part of the ABUS service.

ABUS crane systems and components:



Overhead Cranes



Jib Cranes



HB light crane track systems

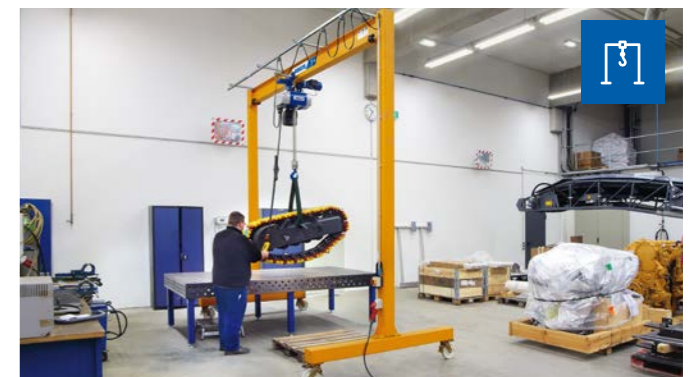

Lightweight mobile gantry LPK



Electric Wire Rope Hoists



Electric Chain Hoists and High-Performance Components

Complete solutions from ABUS

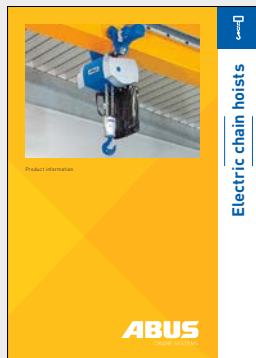

You can find further product information on our entire product portfolio at:
<https://www.abuscranes.com/downloads>

PUBLISHER

ABUS Kransysteme GmbH
 P. O. 10 01 62
 51601 Gummersbach · Germany
 Phone + 49 22 61 37-0
 e-mail: info@abuscranes.com

AN 316040 7.23